

User Manual for RGB Controller V5

REV. 2.0 /06-2020/

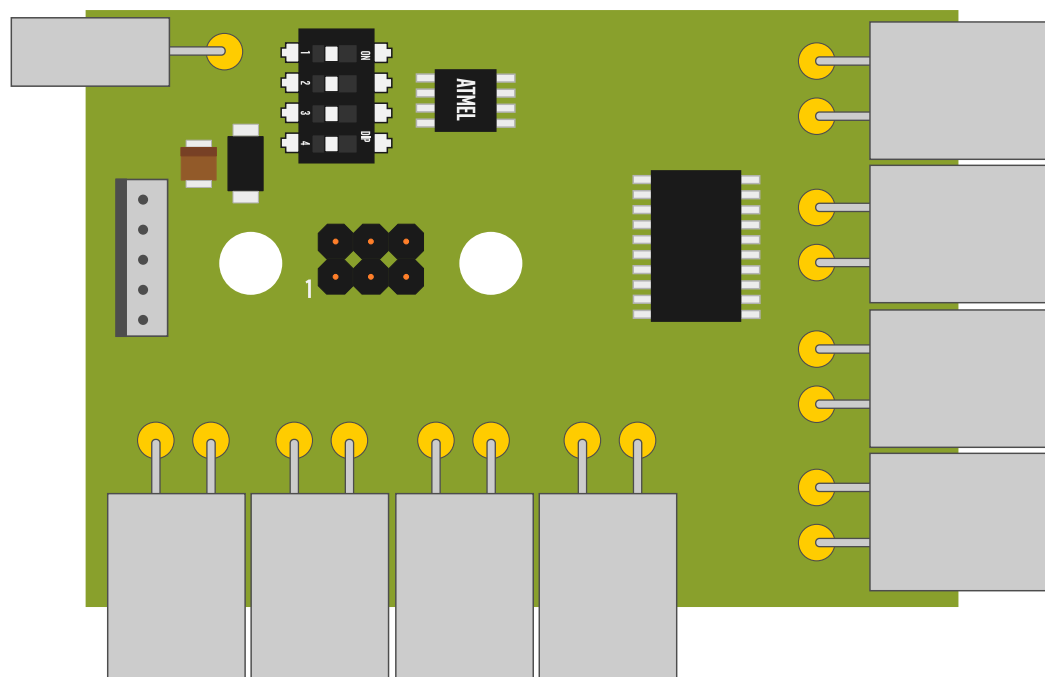

The RGB controller controls 120 LEDs per strip or multiple strips. When connecting more than 120 LEDs, the effects are repeated. The controller can be submitted supply voltage and through connector K1 5V, and maximum current 5A (maximum length of the LED diode strip is 2 meters). If necessary to control more than 2 meters LED diode strip power is connected directly to the strip.

The main management options are:

- Passive - via DSW.
- Active via connector K1, in this case all DSW switches are required to be in (OFF) position. The table describes all the options for switching on color effects via DSW. The (ON) position of DSW connected (shorted) to (GND) responds on the same pin of connector K1. DSW numbering is the same as connector K1 (position 1 of DSW corresponds to leg 1 of K1).

**The power supply to the controller must exceed 5.6 Volts!
When applying a voltage higher than 5.6 Volts
will cause damage to the controller!**

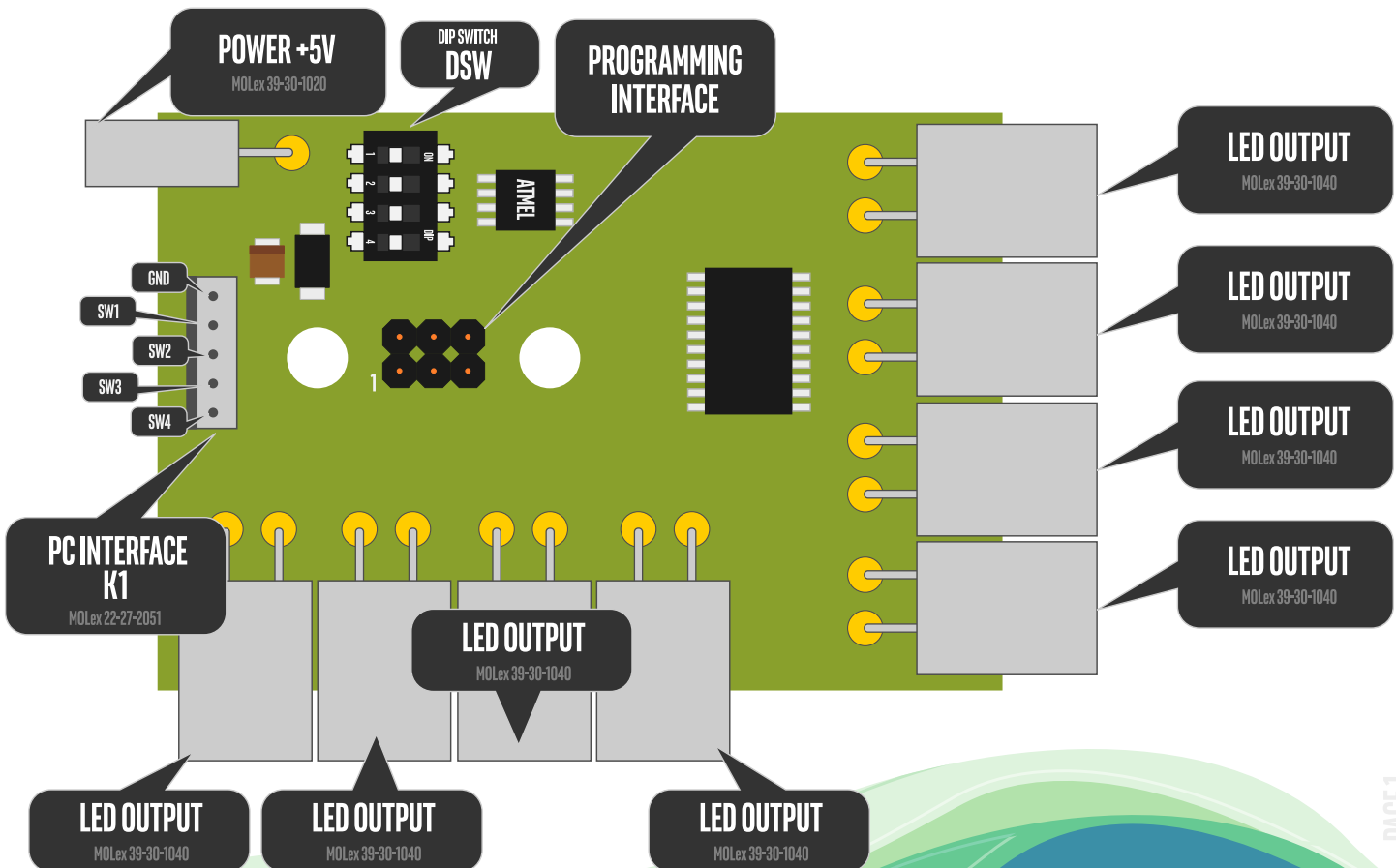

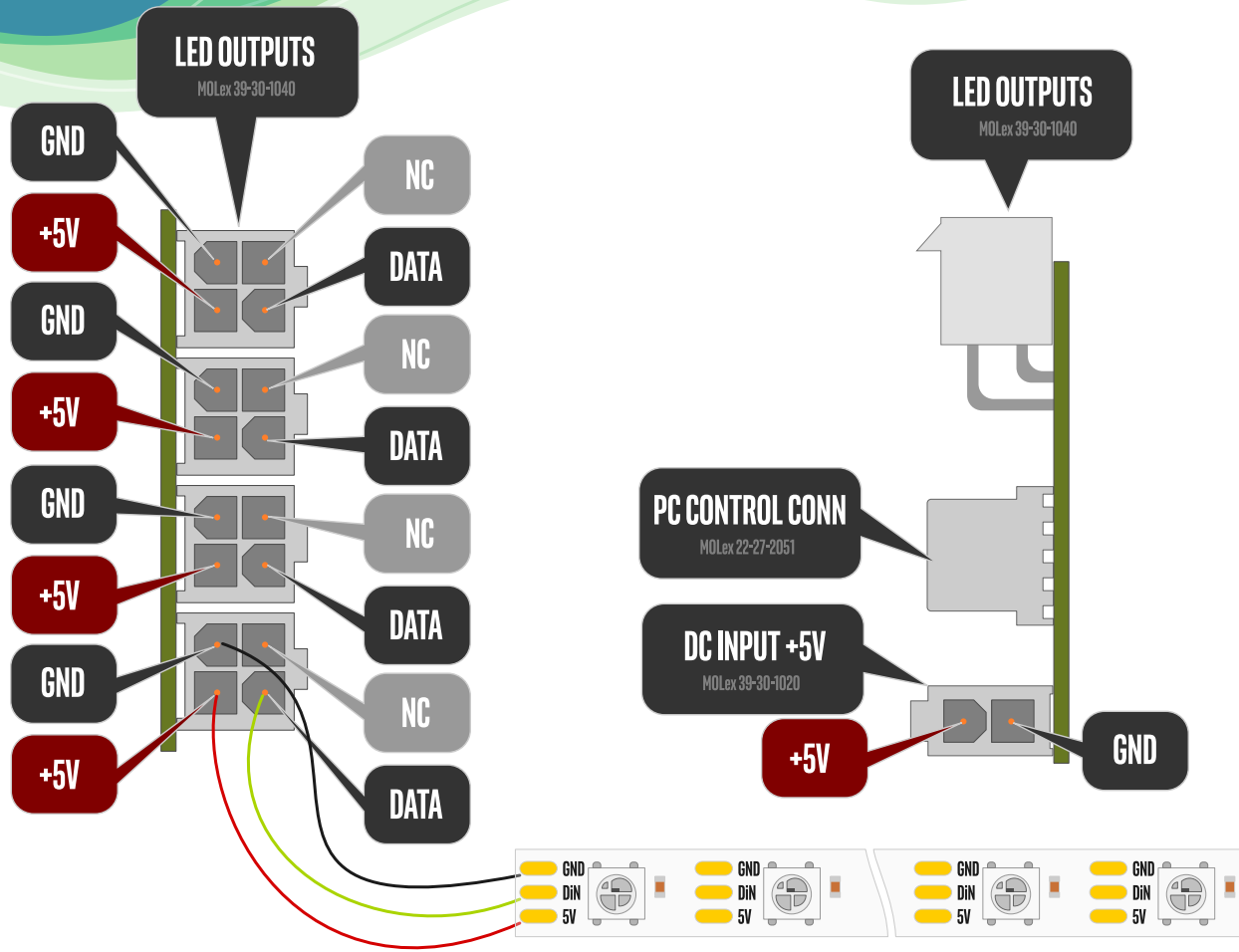

MAX 120 LED

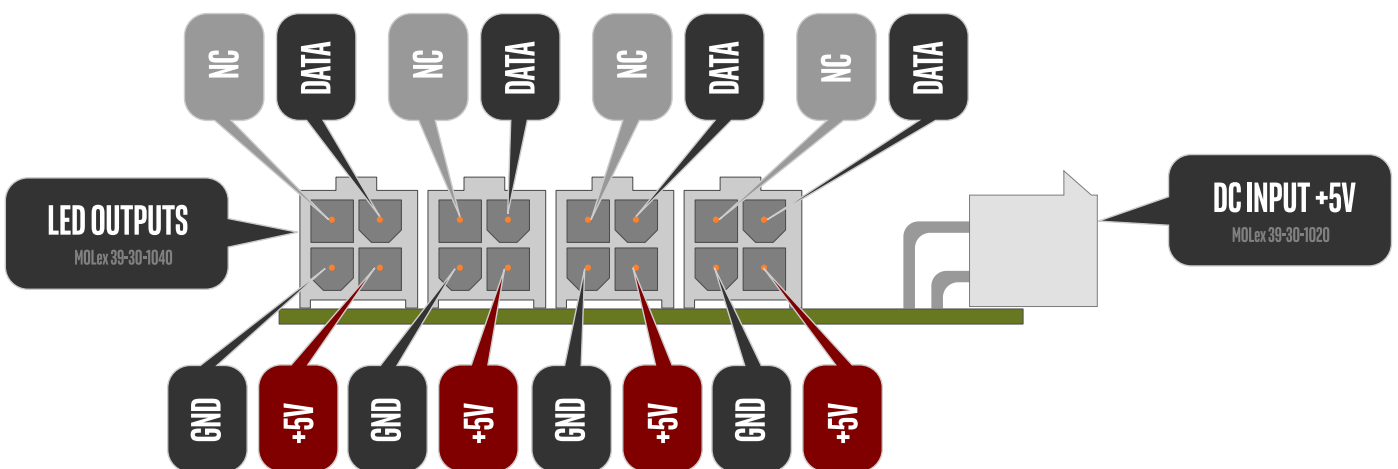

**The power supply to the controller must exceed 5.6 Volts!
When applying a voltage higher than 5.6 Volts
will cause damage to the controller!**



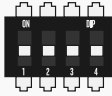

Red / червен

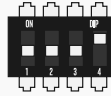

Rainbow / дъга

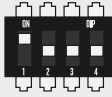

Green / зелен

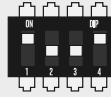

Rainbow One / дъга 1

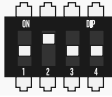

Blue / син

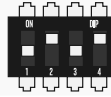

10 Cycles / 10/10-циан-червен

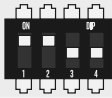

Yellow / жълт

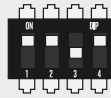

Color Gradient / цветно преливане

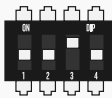

Magenta / магента

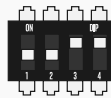

White-Red / бял-червен

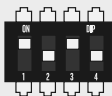

Суан / Циан

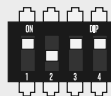

White-Red stripe / бял-червен линия

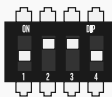

White / Бял

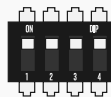

Strobe / стробоскоп ефект

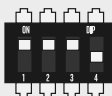

Blackout / зелен

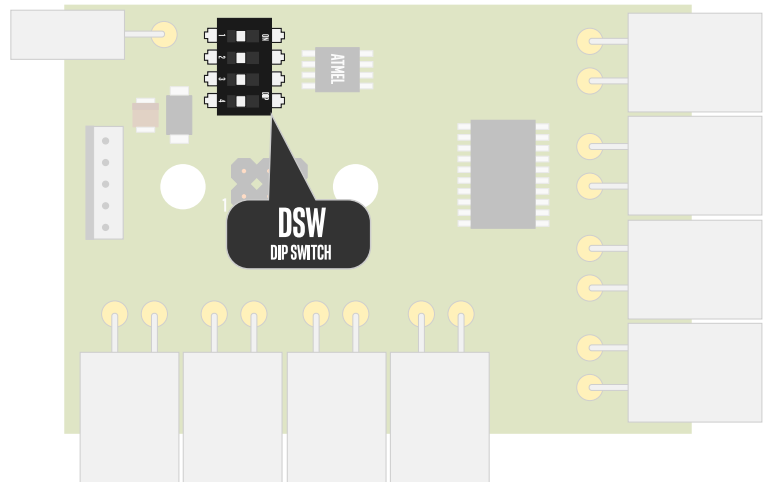

The seller is not responsible for defects, caused by failure to follow instructions by the user.



Technical specification

Consumption 10mA +/-10%

Power supply voltage 5V +/-10%

Size 72x27x15 mm

Location of the pins of CON1

a. PIN 1 +5V

b. PIN 2 GND

Output connectors CON2 & CON3

a. PIN 1 +5V

b. PIN 2 GND

c. PIN 3 DATA OUT

d. PIN 4 NC

SERIAL programming CON5

a. PIN 4 MOSI (SERIAL DATA IN)

b. PIN 3 MISO (SERIAL DATA OUT)

c. PIN 2 SCK (SERIAL CLOCK)

d. PIN 5 GND

Work temperature from -55C to +125C

